

- QUICK START GUIDE -

MixPre-3

Audio Recorder | Mixer | USB Interface



SOUND  **DEVICES**

Welcome

Thank you for purchasing the MixPre-3. This Quick Start Guide provides the initial steps necessary to set up and begin using the MixPre-3. The following table shows what is included in the box.

QUANTITY	ITEM
1	MixPre-3
1	MX-4AA, a battery sled that holds four AA batteries (not included)
1	Y-cable USB-C to two USB-A
1	Anti-rotation pin
1	Allen wrench
1	Registration Card
1	Quick Start Guide

After receiving your purchase, remove all contents from the box to ensure there are no missing parts and that all parts were received without damage.

Featured Usage

The MixPre-3 is an incredibly versatile audio recorder that is ideal for the following scenarios, and more.



Musicians

- Singer/Song Writer
- Live Performance
- Music Recitals



Videographers

- Audio for DSLRs



Field Recording

- Interviews / Podcasts
- Corporate Meetings
- Nature Recording

Read and Register...

Sound Devices strongly encourages you to register your product. Registration extends your warranty and ensures you will receive timely updates.

For a full description of all product features, user-based procedures, specifications, and safety information, please refer to the product's User Guide located on the Sound Devices website. Use the QR code or respective link to access and download the guide.

Full User Guide

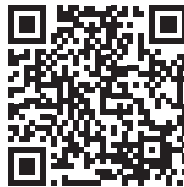

www.sounddevices.com/download/guides/MixPre3-UG_en.pdf

Register Your Product



www.sounddevices.com/support/registration/

Email Support



support@sounddevices.com

Call Support



1-608-524-0625
1-800-505-0625

 Use of this product is subject to acceptance of the end-user license agreement (EULA) provided in the online User Guide.

1. Choose a Power Source & 2. Insert SD Card

The MixPre-3 may be powered via:

- **AA Batteries** - The MX-4AA battery sled holds four AA batteries. An optional MX-8AA sled accessory holds eight AA batteries. Sound Devices recommends using NiMH rechargeable AA cells.
- **L-Mount Batteries** - The optional MX-LMount sled holds two Lithium-Ion batteries.
- **Computer** - Use the USB-C to USB-A Y-Cable or a USB-C to USB-C cable.
- **AC Wall Outlet** - The optional MX-Charge comes with a USB-C plug and several universal wall adapters.

To insert batteries and an SD card:

1. Press the release tab at one end of the battery sled to remove it and access the back panel.
2. Insert batteries into the sled.
3. Insert approved SD card into the slot provided.
4. Reattach battery sled.

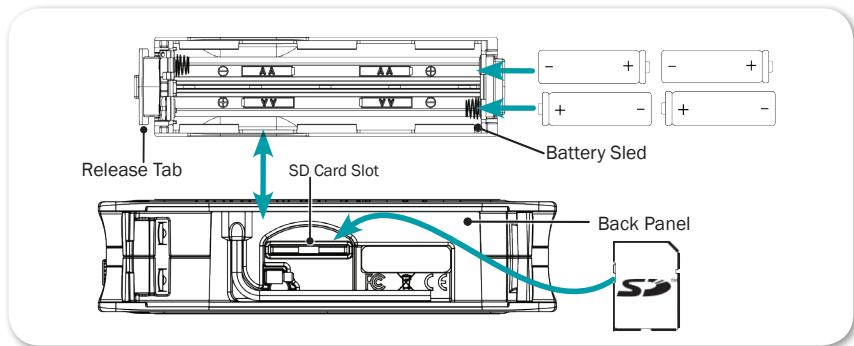

To power the MixPre-3 from a computer:

- ▶ Connect the USB Y-cable to the MixPre-3's USB-C port and two USB-A ports on a computer.

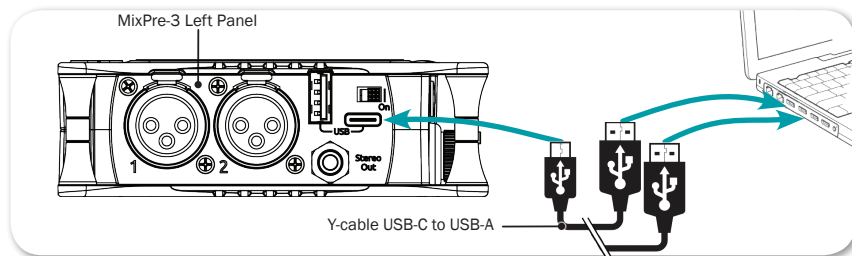

- ▶ Connect a USB-C to USB-C cable to the MixPre-3 and a USB-C power source.

To power the MixPre-3 from an AC wall outlet:

- ▶ Connect the MX-Charge external USB-C Wall Adapter accessory to the USB-C port on the MixPre-3 and an electrical outlet.

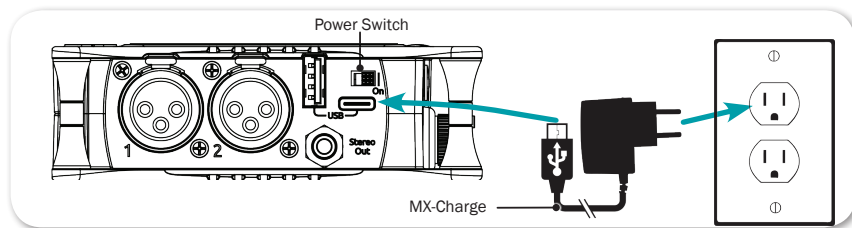

To power on your MixPre-3:

- ▶ Slide the Power switch—located on the left panel—to ON.

Home Screen

The MixPre-3's touch screen displays important metering and record information at a glance on the Home screen.

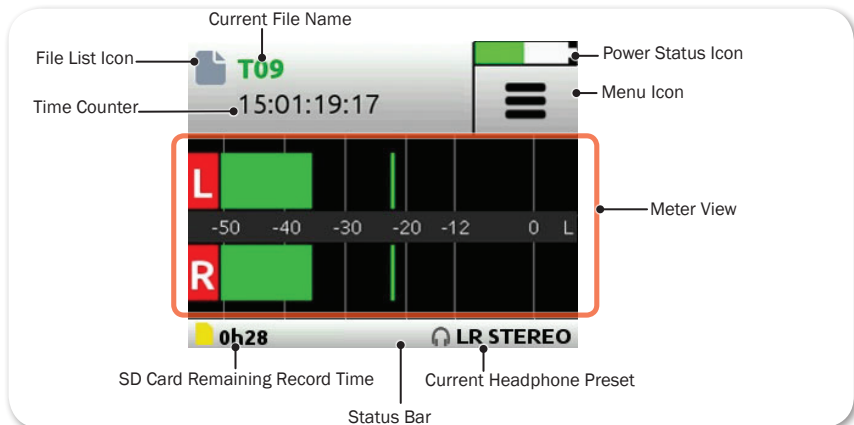

FEATURE	DESCRIPTION
File List icon	Tap this icon to view the list of recorded files.
Current file name	The name of the current file appears red when recording and green when playing.
Power status icon	Displays an icon representing type of power source (USB or battery); the battery icon also indicates the current batteries' remaining power level.
Menu icon	Tap this icon to access the main Menu screen. When displaying menus, this icon changes to the Home icon.
Meter view	The stereo meter view shows the left and right mix channels
Status bar	Tap the status bar to toggle through three views of information that includes date and time, current headphone preset, remaining record time, sample rate and bit depth.
Time counter	Displays elapsed time or timecode, which is stamped on each recorded file and can help simplify audio-to-video synchronization during post-production editing.

3. Format SD Card

SD cards used with the MixPre-3 must be formatted by the MixPre-3.

To format the SD Card:

1. Power on the MixPre-3.
2. Tap .
[There are three pages of Menu settings, as indicated by dots. The solid black dot denotes which page is displayed.]
3. Tap Menu (dots) to view the 2nd page of settings.



4. Tap Card > Edit > Format.

⚠ This will erase all contents of the SD Card!

5. When asked to confirm the command to format the card, tap OK.

The status bar displays the SD card's remaining record time, which will vary based on the storage capacity of the card being used. Other variables that affect digital recording times include concurrent audio track count, sample rate, and bit depth. Here are some record time estimates for a 16 GB SD card.

FORMAT & RATE	TRACKS	RECORDING TIME
WAV - 48 kHz / 24 bits	2	16 hours 11 minutes
WAV - 48 kHz / 24 bits	5	6 hours 28 minutes
WAV - 96 kHz / 24 bits	2	8 hours 5½ minutes

📖 For help determining storage capacity, see Sound Devices' free Audio Record Time Calculator at: <https://www.sounddevices.com/tech-notes/audio-record-time-calculations>.

4. Connect an Audio Source

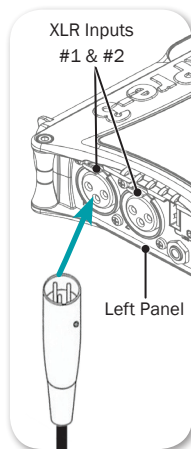

The MixPre-3 provides versatile connectivity options for a wide variety of recording applications. Channels 1-3 can be sourced from the XLR inputs, the Aux/Mic Input, or USB 1-2 inputs.

To connect an audio source:

- ▶ Using a standard XLR cable, connect an audio source to any of three XLR inputs—#1 and 2 on the left panel, #3 on the right panel.
- ▶ Plug a USB audio source into the USB-C port on the MixPre-3.
- ▶ Plug an unbalanced line or plug-in-power (PIP) mic audio source into the Aux/Mic In 3.5 mm TRS connection.

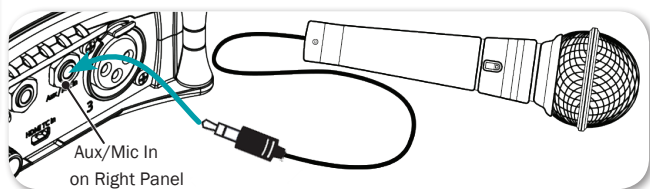

5. Connect Headphones

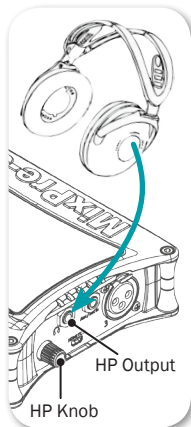

To connect headphones:

- ▶ Plug in the headphones cable to the headphone output located on the right panel.

⚠ The MixPre-3 can drive headphones to very loud levels. Take care when attaching headphones and setting the headphone gain.

To adjust headphone gain:

- ▶ Turn the HP knob, located on the right panel of the MixPre-3.

6. Set up Channels

To set up channels:

1. Press the rotary knobs for the chosen channel. The Channel Settings screen appears on the touch-screen LCD.

The Channel Settings screen appears differently depending on the System > Mode setting, so Input might be on the second page of settings.

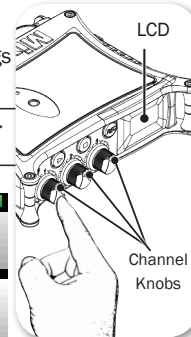
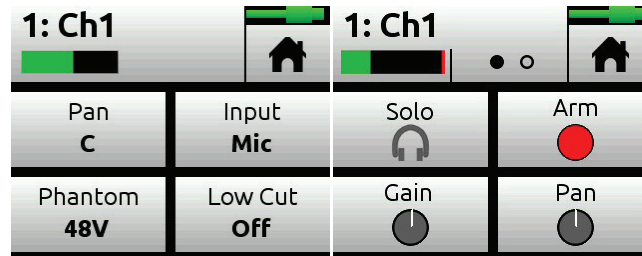

2. Tap Input and select from one of the following input types:

INPUT TYPES	DESCRIPTION
Mic	Use for microphones. For condenser mics requiring 48v phantom power, set Phantom to On.
Line	Use for balanced analog line level sources.
Aux In 1,2	Use for unbalanced stereo input.
USB 1,2	Use for USB audio sources.
Off	Turns the input off.

3. Tap Low Cut to set low-cut filter levels—ideal for reducing wind or mic handling noise.
4. Tap Pan to adjust the input's pan.

7. Adjust Mix Levels

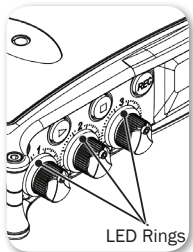

To adjust the mix levels of each channel:

- ▶ Turn the channel knobs.

To assist in setting levels, LED rings around each of the three channel knobs illuminate in various colors:

- Solid Green - the louder the signal, the brighter the LED
- Red - when peaking
- Orange - when limiting
- Blinking Orange - when soloed

8. Connect Timecode Input (Optional)

The MixPre-3 has an internal Time-of-Day clock that can be used for timecode, but an external source for timecode may also be used via HDMI or the Aux/Mic In 3.5 mm connection on the MixPre-3's right side panel. The Aux/Mic In port provides two unbalanced channels through which to receive timecode.

To connect timecode:

1. Connect a timecode source to appropriate port. For instance, connect an external timecode generator to the Aux/Mic In port. For DSLR cameras that supports HDMI timecode, connect the HDMI out from the camera to the HDMI TC In port on the MixPre-3.

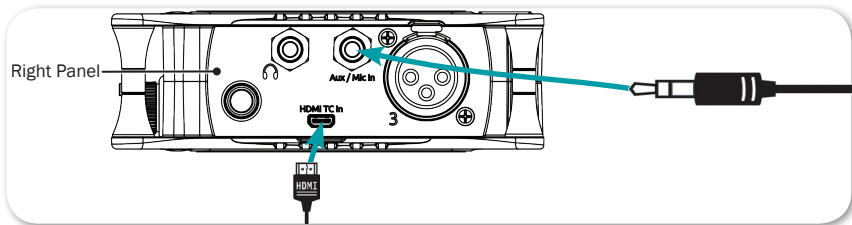

2. Tap .
3. Select Inputs > Aux In Mode, and then select Timecode.
4. Select Timecode > Mode. Options include: Off, Aux In 1, Aux In 2, and HDMI TC In.

9. Record and Playback

There are three illuminated transport controls on the front panel of the MixPre-3 for recording and playback operations.

To use transport controls:

- ▶ Press the REC button to record.
- ▶ Press the Stop (■) button to stop recording or playback.
- ▶ Press the Play (▶) button to play a recorded file.

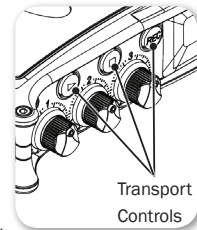

Recording may also be triggered from rolling timecode or from compatible DSLR cameras with HDMI output.

To set up Record Triggering:

1. Tap .
2. Select Record > Rec Trigger. Options include: Off, HDMI flag, and Timecode.

Typical Applications: Audio Recording

The following illustration shows one example of how the MixPre-3 may be connected to different external microphones for recording audio, such as dialog, sound effects, nature recording, and other similar in-the-field audio applications.

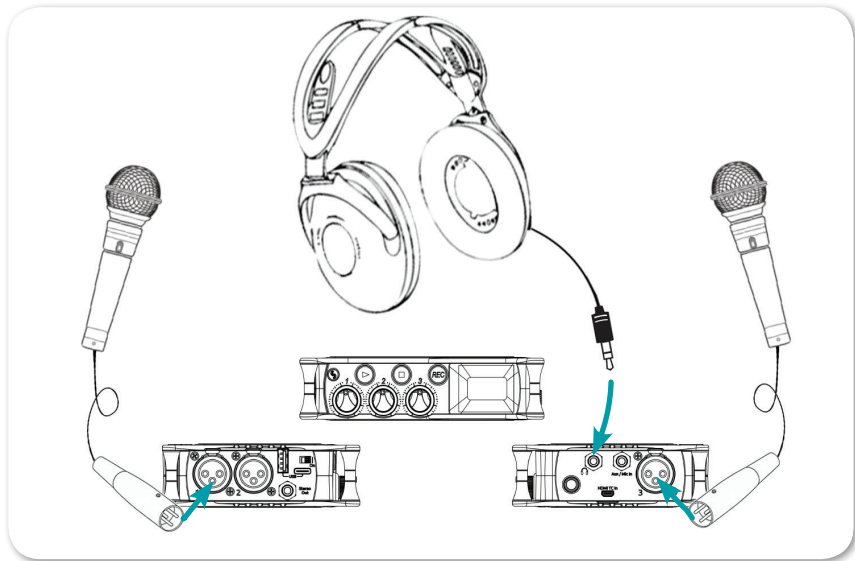

Typical Applications: Music Recording

The following illustration of a sample musical recording setup shows one example of how the MixPre-3 may be connected to external devices—such as musical instruments, microphones, computers, and speakers and headphones for monitoring.

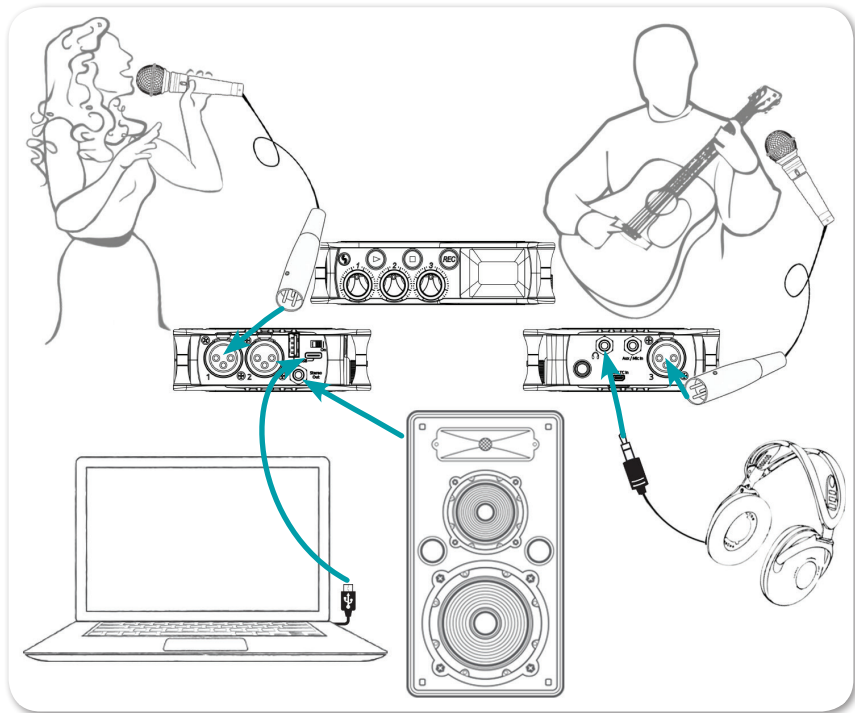

Typical Applications: Videography

The following illustration shows an example of how the MixPre-3 may be used with a DSLR camera in sound-for-video applications.

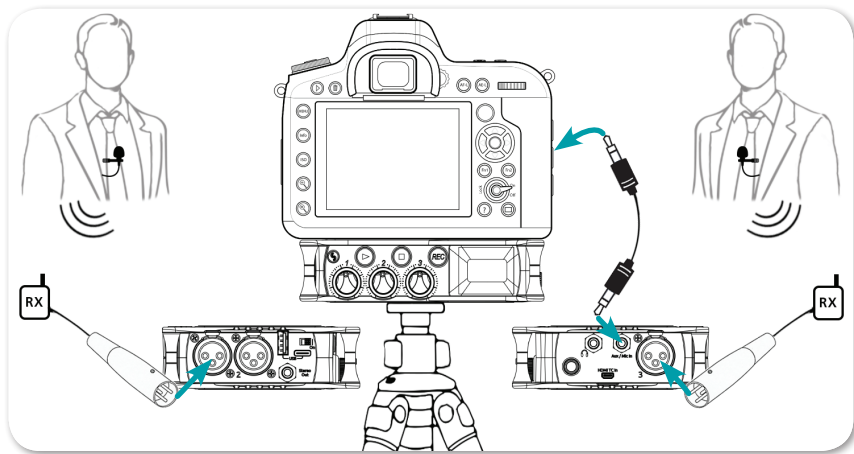

- ☐ To monitor return from the camera, connect the camera's analog audio output to the 3.5 mm Aux/Mic In on the MixPre-3, and set Inputs > Aux In Mode to Return.

Using the MixPre-3 with a Camera and/or Tripod

The MixPre-3 has 1/4-inch, 20-threaded screw mounting options on the top and bottom panels, so it may be mounted to gear in a variety of ways. For instance, when mounting between a tripod and camera, attach it to the bottom of the camera first before screwing it into place atop the tripod.

To attach the MixPre-3:

1. Remove the battery sled to gain access to the back panel.
2. Retrieve the anti-rotation pin and Allen wrench. Both are magnetically held in place on the back panel.

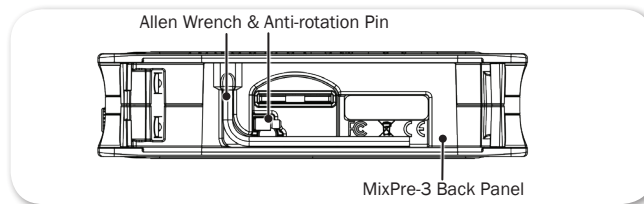

3. (Optional) If your camera has a slot for the anti-rotation pin, screw the pin into place on top of the MixPre-3, and then position the MixPre-3 against the bottom of the camera so that the pin fits into the camera's slot.

- ☐ The anti-rotation pin may also be screwed into a tripod and slotted into the bottom of the MixPre-3.

4. From the MixPre-3's bottom panel, insert the Allen wrench into the mounting screw hole and push up on the retractable screw. Rotate to screw the MixPre-3 into place underneath camera.
5. Align the mounting screw hole on the bottom panel with the mounting screw on the tripod, and screw into place.

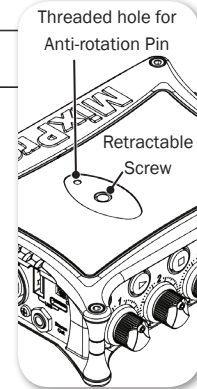
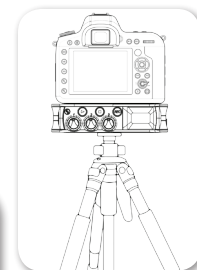

Enabling Wireless Remote Control, Using the Wingman App

The MixPre-3 has built-in Bluetooth Smart® functionality that allows for remote control and monitoring from the Wingman™ app.

Sound Devices Wingman, which is a free download from Google Play and Apple's App Store, is a wireless interface that gives users touch-screen access to monitor meters, start and stop recordings, and edit filenames and metadata on the MixPre-3 directly from any Android mobile device running Android 5.0 or later, as well as any iPad, iPhone or iPod Touch device running iOS 8.0 or later.



To turn on Bluetooth on the MixPre-3:

1. Tap .
2. Tap System > Bluetooth. Options include Off and On.

Warranty and Service

Sound Devices, LLC strongly encourages you to register your product. Registering can extend your warranty and ensure you will receive timely updates.

Register online here: www.sounddevices.com/support/registration

Read your warranty here: www.sounddevices.com/support/warranty

For all service, including warranty repair, please contact Sound Devices for an RMA (return merchandise authorization) before sending your unit in for repair. Product returned without an RMA number may experience delays in repair. When sending a unit for repair, please do not include accessories, including SSD drives, CF cards, batteries, power supplies, carry cases, cables, or adapters unless instructed by Sound Devices. Sound Devices repairs and replacements may be completed using refurbished, returned or used parts that have been factory certified as functionally equivalent to new parts.

Sound Devices, LLC
Service Repair RMA #XXXXX
E7556 State Road 23 and 33
Reedsburg, WI 53959 USA
Telephone: (608) 524-0625

Technical Support

For technical support and bug reporting on all Sound Devices products contact Sound Devices, LLC at:

E-mail: support@sounddevices.com
Website: www.sounddevices.com/support/

To report technical errors in this guide,
email: techpubs@sounddevices.com

Phone: +1 (608) 524-0625
Toll-free: +1 (800) 505-0625 — in USA only
Fax: +1 (608) 524-0655

Fill In and Keep for Your Records

PRODUCT: _____
SERIAL NUMBER: _____
PURCHASE DATE: _____
STORE/RETAILER: _____

Legal Notes

Product specifications and features are subject to change without prior notification.

Copyright © 2017
Sound Devices, LLC.
All rights reserved.

This document is protected under copyright law. An authorized licensee of this product may reproduce this publication for the licensee's own personal use. This document may not be reproduced or distributed, in whole or in part, for commercial purposes, such as selling copies or providing educational services or support. This document is supplied as a technical guide. Special care has been taken in preparing the information for publication; however, since product specifications are subject to change, this document might contain omissions and technical or typographical inaccuracies. Sound Devices, LLC does not accept responsibility for any losses due to the use of this guide.

Limitation of Liability

LIMITATION ON SOUND DEVICES' LIABILITY. SOUND DEVICES, LLC SHALL NOT BE LIABLE TO THE PURCHASER OF THIS PRODUCT OR THIRD PARTIES FOR DAMAGES, LOSSES, COSTS, OR EXPENSES INCURRED BY PURCHASER OR THIRD PARTIES AS A RESULT OF: ACCIDENT, MISUSE, OR ABUSE OF THIS PRODUCT OR UNAUTHORIZED MODIFICATIONS, REPAIRS, OR ALTERATIONS TO THIS PRODUCT, OR FAILURE TO STRICTLY COMPLY WITH SOUND DEVICES, LLC'S OPERATING AND INSTALLATION INSTRUCTIONS. TO THE FULLEST EXTENT PERMITTED BY LAW, SOUND DEVICES SHALL HAVE NO LIABILITY TO THE END USER OR ANY OTHER PERSON FOR COSTS, EXPENSES, DIRECT DAMAGES, INCIDENTAL DAMAGES, PUNITIVE DAMAGES, SPECIAL DAMAGES, CONSEQUENTIAL DAMAGES OR OTHER DAMAGES OF ANY KIND OR NATURE WHATSOEVER ARISING OUT OF OR RELATING TO THE PRODUCTS, THESE TERM/S AND CONDITIONS OR THE PARTIES' RELATIONSHIP, INCLUDING, WITHOUT LIMITATION, DAMAGES RESULTING FROM OR RELATED TO THE DELETION OR OTHER LOSS OF AUDIO OR VIDEO RECORDINGS OR DATA, REDUCED OR DIMINISHED AUDIO OR VIDEO QUALITY OR OTHER SIMILAR AUDIO OR VIDEO DEFECTS ARISING FROM, RELATED TO OR OTHERWISE ATTRIBUTABLE TO THE PRODUCTS OR THE END USER'S USE OR OPERATION THEREOF, REGARDLESS OF WHETHER SUCH DAMAGES ARE CLAIMED UNDER CONTRACT, TORT OR ANY OTHER THEORY. "CONSEQUENTIAL DAMAGES" FOR WHICH SOUND DEVICES SHALL NOT BE LIABLE SHALL INCLUDE, WITHOUT LIMITATION, LOST PROFITS, PENALTIES, DELAY DAMAGES, LIQUIDATED DAMAGES AND OTHER DAMAGES AND LIABILITIES WHICH END USER SHALL BE OBLIGATED TO PAY OR WHICH END USER OR ANY OTHER PARTY MAY INCUR RELATED TO OR ARISING OUT OF ITS CONTRACTS WITH ITS CUSTOMERS OR OTHER THIRD PARTIES. NOTWITHSTANDING AND WITHOUT LIMITING THE FOREGOING, IN NO EVENT SHALL SOUND DEVICES BE LIABLE FOR ANY AMOUNT OF DAMAGES IN EXCESS OF AMOUNTS PAID BY THE END USER FOR THE PRODUCTS AS TO WHICH ANY LIABILITY HAS BEEN DETERMINED TO EXIST. SOUND DEVICES AND END USER EXPRESSLY AGREE THAT THE PRICE FOR THE PRODUCTS WAS DETERMINED IN CONSIDERATION OF THE LIMITATION ON LIABILITY AND DAMAGES SET FORTH HEREIN AND SUCH LIMITATION HAS BEEN SPECIFICALLY BARGAINED FOR AND CONSTITUTES AN AGREED ALLOCATION OF RISK WHICH SHALL SURVIVE THE DETERMINATION OF ANY COURT OF COMPETENT JURISDICTION THAT ANY REMEDY HEREIN FAILS OF ITS ESSENTIAL PURPOSE.

Trademarks

The "wave" logo and USBPre are registered trademarks of Sound Devices, LLC. Mac and OS X are trademarks of Apple Inc., registered in the U.S. and other countries. Windows is a registered trademark of Microsoft Corporation in the United States and other countries.



This device complies with part 15 of the FCC Rules. Operation is subject to the following two conditions: (1) This device may not cause harmful interference, and (2) this device must accept any interference received, including interference that may cause undesired operation.

FCC Part 15.19 (a) (3)

Full FCC compliance information may be found in the product's User Guide found at www.sounddevices.com.



Caution: Incorrect use of batteries poses a danger of explosion. Replace only with the same or equivalent type. Properly recycle batteries. Do not crush, disassemble, incinerate, dispose in a fire or expose batteries to high temperatures.

SOUND  **DEVICES**

Declaration of Conformity



Manufacturer's Name: Sound Devices, LLC
Manufacturer's Address: E7556 State Road 23 and 33
Reedsburg, WI 53959
USA

Declares under sole responsibility that the product as delivered

Product Name: MixPre-3 Audio Recorder & USB Audio Interface
Model Number: MixPre-3
Description: Portable audio recorder with mixing & Bluetooth capabilities
Product Options: This declaration covers all options of the above product.

complies with the essential requirements of the following applicable European Directives, and carries the CE marking accordingly:

Radio Equipment Directive (2014/53/EU)

Article 3.1b:

ETSI EN 301 489-17 v3.1.1
EN 55032:2012
EN 55032:2/AC:2013
CISPR 32:2012
EN 55103-2:2009

Article 3.2:

ETSI EN 300 328 v2.1.1



This Declaration of Conformity applies to the above-listed product(s) placed on the EU market after:

April 19, 2017

Date

Matt Anderson - Sound Devices, LLC President

SOUND  **DEVICES**

www.sounddevices.com

FC   CE
Part # 7375.003